

PROFESSIONAL GRADE EQUIPMENT

Made in the USA

ProVac

Industrial Pumpout System

GAS POWERED

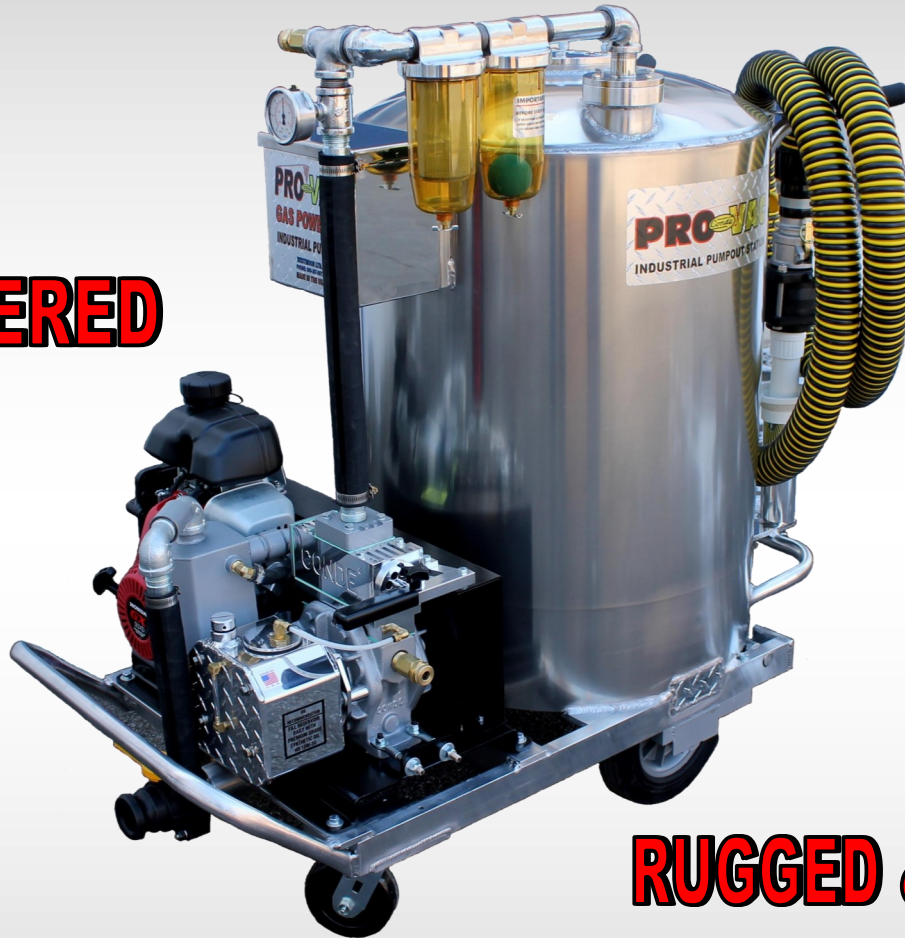

RUGGED & RELIABLE

STANDARD FEATURES:

- Constructed of Lightweight Aluminum
- Automatic Oiling System
- Honda (GX100QA2) Pull Start Engine
- User Friendly / Easy Access Controls
- Tool Box
- Primary Float Shutoff
- Secondary Trap with Drain
- Pump Pre-Filter Strainer with Drain
- 25-1/2" Width
- 48" Height

- Liquid Filled Vacuum / Pressure Gauge
- Oil Catch Muffler with Drain
- Wand Holder with Drain
- 2" x 10 FT Plastiflex Suction Hose
- Hose Wand Assembly
- Two - 6" Cleanout Manways
- Heavy Duty Wheels & Swivel Casters
- Hand / Parking Brake
- Vacuum & Pressure Relief Valves
- Pump Flush Valve
- 120 Gallon Per Minute Pumping

PRO-VAC

PERFORMANCE BY DESIGN GAS POWERED INDUSTRIAL PUMPOUT UNIT

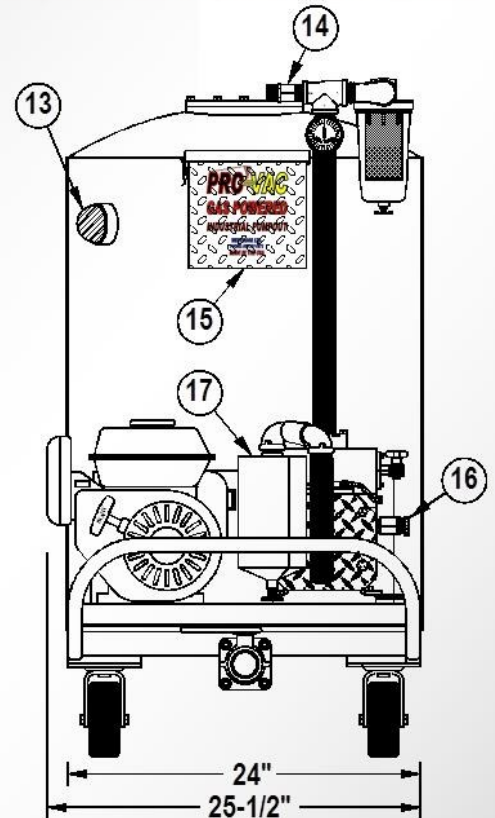
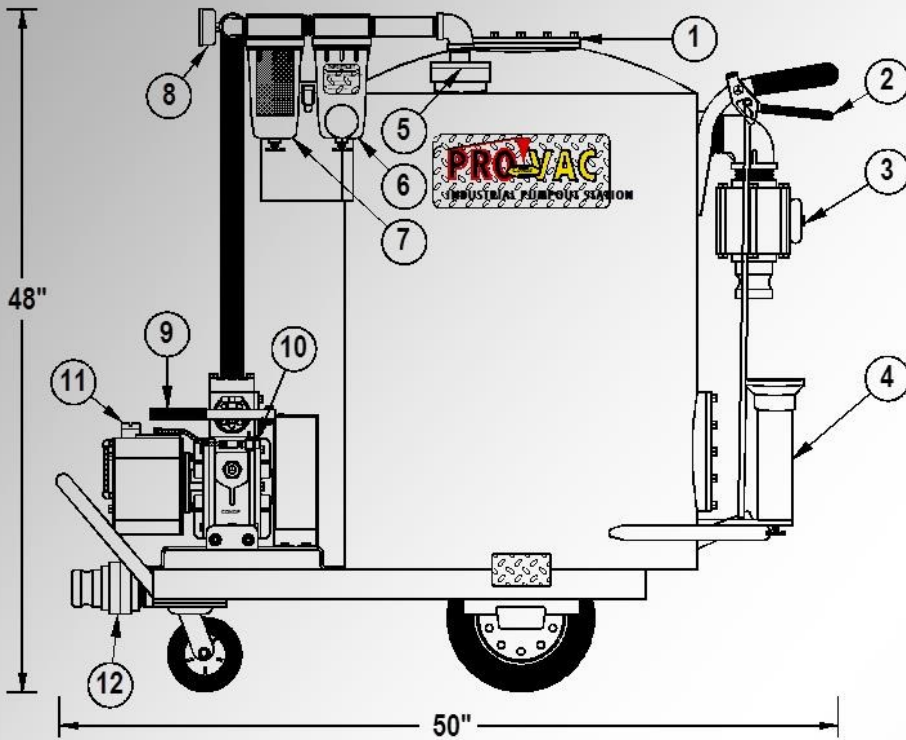

PART NO.

LWUNP60GAS - PROVAC 60 GALLON (ALUMINUM) GAS POWERED UNIT

DRY WEIGHT - 250#

STANDARD FEATURES

CONDE' PROVAC VACUUM/PRESSURE PUMP (35 CFM)
 AUTOMATIC OILING SYSTEM
 2" SUCTION INLET & DISCHARGE OUTLET
 HONDA (GX100QA2) PULL START ENGINE
 PRIMARY & SECONDARY SHUT OFFS
 PUMP PRE-FILTER STRAINER
 OIL CATCH MUFFLER W/ DRAIN
 LIQUID FILLED VACUUM/PRESSURE GAUGE
 10 FT - 2" PLASTIFLEX SUCTION HOSE W/ WAND ASSEMBLY
 TWO - 6" CLEANOUT MANWAYS
 HEAVY DUTY WHEELS & FRONT CASTORS
 HAND / PARKING BRAKE
 VACUUM & PRESSURE RELIEF VALVES
 PUMP FLUSH VALVE

NO. PART IDENTIFICATION

- 1 - CLEANOUT MANWAY
- 2 - BRAKE HANDLE
- 3 - SUCTION INLET BALL VALVE
- 4 - WAND HOLDER
- 5 - PRIMARY SHUTOFF
- 6 - SECONDARY TRAP
- 7 - PUMP PRE-FILTER STRAINER
- 8 - VACUUM / PRESSURE GAUGE
- 9 - MODE POSITIONING HANDLE
- 10 - PUMP - FLUSH VALVE
- 11 - OIL RESERVOIR
- 12 - TANK OUTLET BALL VALVE
- 13 - SIGHT GLASS
- 14 - PRESSURE RELIEF VALVE
- 15 - TOOL BOX
- 16 - VACUUM RELIEF VALVE
- 17 - OIL CATCH MUFFLER

BUILT TO LAST

WWW.WESTMOORLTD.COM

VACUUM TECHNOLOGY



WESTMOOR LTD.

**906 WEST HAMILTON AVE
 SHERRILL, NY 13461**

PHONE: 1-800-367-0972