



Est. 1939

SUPER 6 Vacuum Pump

70 CFM

MADE IN

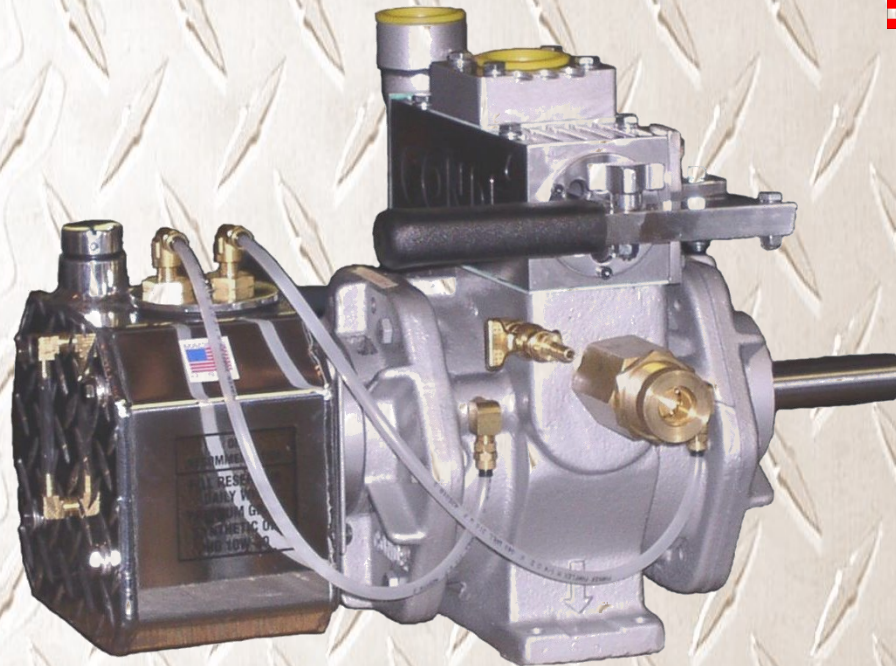

WITH ALL THE SAME FEATURES FOUND ON LARGER PUMPS

* **Versatile - Double Shaft Design**

Pump can be clockwise or counterclockwise rotation. Simply mount oil reservoir on either end.

* **Automatic Oiling**

Conde Automatic oilers require no adjustment. Simply add oil.

* **Available in Vacuum only or Vacuum / Pressure**

Vacuum / Pressure models include built in check valve to hold tank vacuum, and vacuum relief valve mounted on pump.

* **Sealed Bearings - Require NO MAINTENANCE.**

* **End Thrust Protection To Prevent End Plate to Rotor Wear.**

* **ONE YEAR WARRANTY !**



SUPER 6

DIMENSIONAL SPECIFICATIONS

#6 SUPER (VACUUM)

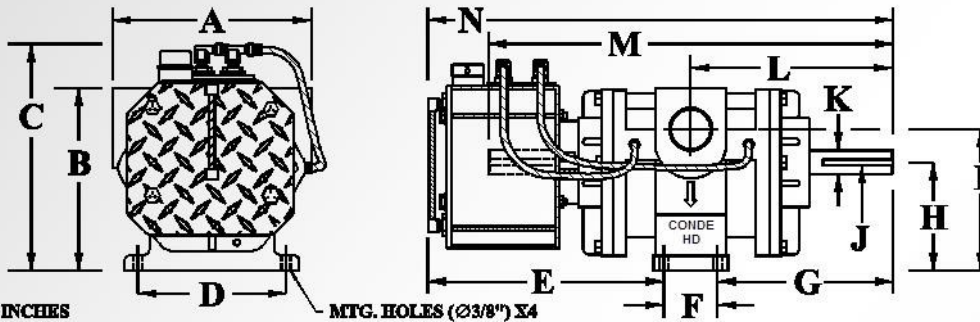

ALL DIMENSIONS IN INCHES

MTG. HOLES (Ø3/8") X4

A	B	C	D	E	F	G	H	I	J	K	L	M	N
8	7-5/8	8-7/8	6-1/4	9-3/4	2-1/4	7-1/8	4-9/16	5-15/16	1/4 key	Ø 1	8-1/4	16-1/2	19-1/8

#6 SUPER (VAC./PRESS.)

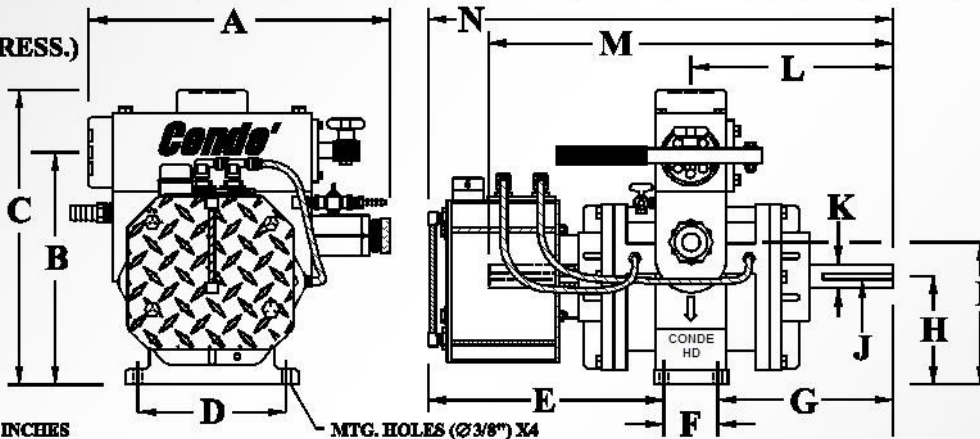

ALL DIMENSIONS IN INCHES

MTG. HOLES (Ø3/8") X4

A	B	C	D	E	F	G	H	I	J	K	L	M	N
13	9-1/8	12	6-1/4	9-3/4	2-1/4	7-1/8	4-9/16	5-15/16	1/4 key	Ø 1	8-1/4	16-1/2	19-1/8

PERFORMANCE DATA

PUMP RPM	DISPLACEMENT CFM	SCFM @ VACUUM				
		5	10	15	18	20
1200	48	36	32	27	21	15
1500	60	45	39	34	27	18
1750	70	52	46	40	31	21

PUMP RPM	DISPLACEMENT CFM	SCFM @ PRESSURE				
		2	4	8	12	15
1200	48	47	47	46	46	45
1500	60	59	59	58	57	57
1750	70	69	68	67	67	66

SPEED RANGE	1100 THRU 1750 RPM
MAXIMUM VACUUM	27" HG INTERMITTENT 20" HG CONTINUOUS
LUBRICATION	CONDE AUTOMATIC
PORT CONNECTION	1-1/4 - 11.5 NPT
SHAFT DIAMETER	1.0"
WEIGHT (VACUUM)	70 LBS
WEIGHT (VAC./PRESS.)	75 LBS

WESTMOOR LTD.
906 WEST HAMILTON AVE
SHERRILL, NY 13461

PHONE: 800-367-0972
WWW.WESTMOORLTD.COM